

SCM5B35

Linearized 4-Wire RTD Input Modules



Description

In RTD temperature measurement applications requiring a very high level of accuracy, the SCM5B35 4-Wire RTD input module offers a significant advantage over 3-wire measurement techniques (Figure 1). The SCM5B35 measures only the voltage dropped across the RTD and almost completely ignores the resistance or length of the RTD lead wires. The SCM5B34 3-Wire RTD module provides lead resistance compensation, but requires equal lead resistances, while the SCM5B35 does not require matched lead resistances.

Each SCM5B35 RTD input module provides a single channel of RTD input which is filtered, isolated, amplified, linearized, and converted to a high level analog voltage output. This voltage output is logic switch controlled, which allows these modules to share a common analog bus without the requirement of external multiplexers.

The SCM5B modules are designed with a completely isolated computer side circuit which can be floated to $\pm 50V$ from Power Common, pin 16. This complete isolation means that no connection is required between I/O Common and Power Common for proper operation of the output switch. If desired, the output switch can be turned on continuously by simply connecting pin 22, the Read-Enable pin, to I/O Common, pin 19.

RTD excitation is provided from the module by a precision current source. The excitation current is available on two leads which are separate from the two input signal measuring leads. The excitation current does not flow in the input signal leads, which allows RTD measurement to be totally independent of lead resistance. The excitation current is very small (0.25mA for 100 Ω Pt and 120 Ω Ni and 1.0 mA for 10 Ω Cu) which minimizes self-heating of the RTD.

Signal filtering is accomplished with a six-pole filter which provides 95dB of normal-mode-rejection at 60Hz and 90dB at 50Hz. Two poles of this filter are

► Features

- Interfaces to 100 Ω Platinum, 10 Ω Copper, or 120 Ω Nickel RTDs
- True 4-Wire Input
- Linearizes RTD Signal
- High Level Voltage Output
- 1500Vrms Transformer Isolation
- ANSI/IEEE C37.90.1-1989 Transient Protection
- Input Protected to 240VAC Continuous
- 160dB CMR
- 95dB NMR at 60Hz, 90dB at 50Hz
- CSA Certified, FM Approved, CE Compliant
- Mix and Match SCM5B Types on Backpanel

on the field side of the isolation barrier, and the other four are on the computer side. After the initial field-side filtering, the input signal is chopped by a proprietary chopper circuit. Isolation is provided by transformer coupling, again using a proprietary technique to suppress transmission of common mode spikes or surges. The module is powered from +5VDC, $\pm 5\%$.

A special input circuit on the SCM5B35 modules provides protection against accidental connection of power-line voltages up to 240VAC.

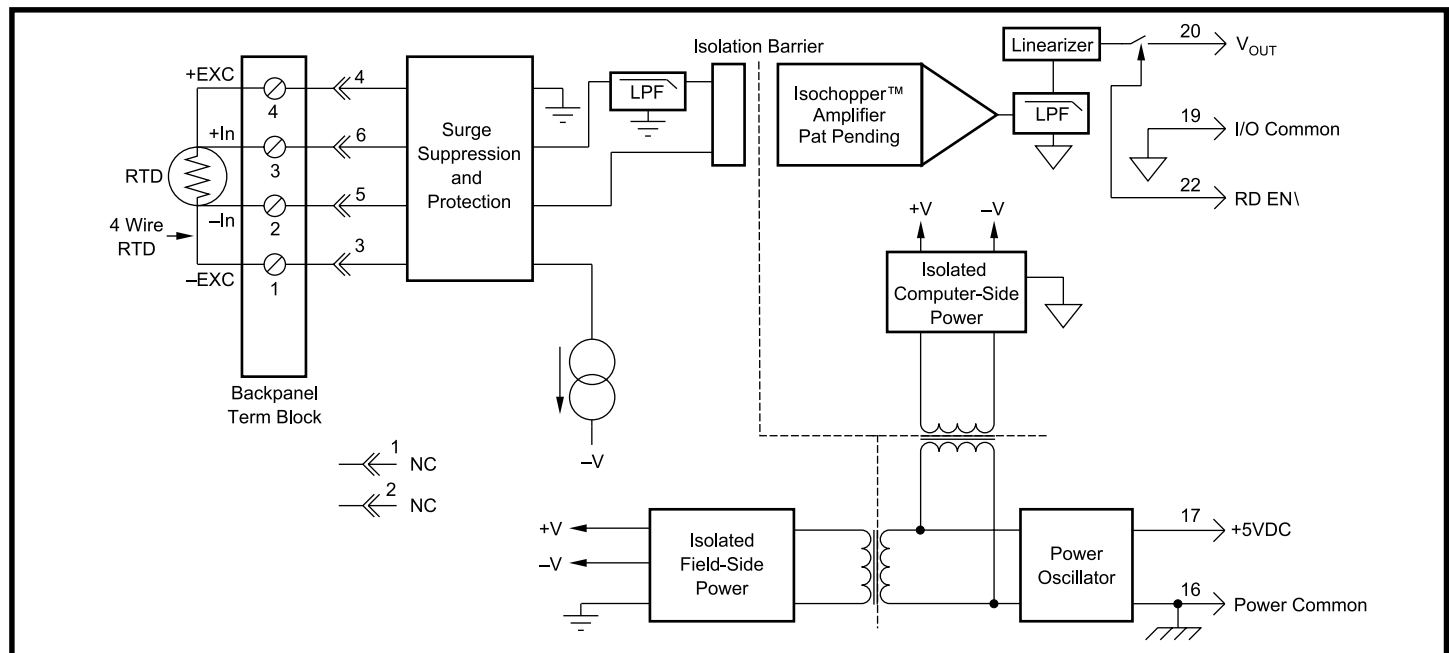

Figure 1: SCM5B35 Block Diagram

Specifications Typical at $T_A = +25^\circ\text{C}$ and +5V power

Module	SCM5B35
Input Range Limits	-200°C to +850°C (100Ω Pt) -80°C to +320°C (120Ω Ni) -100°C to +260°C (10Ω Cu)
Input Resistance	
Normal	50MΩ
Power Off	40kΩ
Overload	40kΩ
Input Protection	
Continuous	240Vrms max
Transient	ANSI/IEEE C37.90.1-1989
Sensor Excitation Current	
100Ω Pt, 120Ω Ni	0.25mA
10Ω Cu	1.0mA
Lead Resistance Effect	
100Ω Pt, 120Ω Ni	$\pm 0.0005^\circ\text{C}/\Omega^{(1)}$
10Ω Cu	$\pm 0.005^\circ\text{C}/\Omega^{(1)}$
CMV, Input to Output	
Continuous	1500Vrms max
Transient	ANSI/IEEE C37.90.1-1989
CMR (50Hz or 60Hz)	160dB
NMR	95dB at 60Hz, 90dB at 50Hz
Accuracy	See Ordering Information
Conformity Error ⁽³⁾	$\pm 0.025\%$ Span
Stability	
Input Offset	$\pm 0.01^\circ\text{C}/^\circ\text{C}$
Output Offset	$\pm 20\mu\text{V}/^\circ\text{C}$
Gain	$\pm 35\text{ppm}$ of Reading/ $^\circ\text{C}$
Noise	
Input, 0.1 to 10Hz	0.2μVrms
Output, 100kHz	200μVrms
Bandwidth, -3dB	4Hz
Response Time, 90% Span	0.2s
Output Range	0V to +5V
Output Resistance	50Ω
Output Protection	Continuous Short to Ground
Output Selection Time (to $\pm 1\text{mV}$ of V_{OUT})	6μs at $C_{\text{load}} = 0$ to 2000pF
Output Current Limit	+8mA
Output Enable Control	
Max Logic "0"	+0.8V
Min Logic "1"	+2.4V
Max Logic "1"	+36V
Input Current, "0,1"	0.5μA
Power Supply Voltage	+5VDC $\pm 5\%$
Power Supply Current	30mA
Power Supply Sensitivity	
100Ω Pt, 120Ω Ni	$\pm 0.2^\circ\text{C}/\text{V}$
10Ω Cu	$\pm 0.5^\circ\text{C}/\text{V}$
Mechanical Dimensions (h)(w)(d)	2.28" x 2.26" x 0.60" (58mm x 57mm x 15mm)
Environmental	
Operating Temp. Range	-40°C to +85°C
Storage Temp. Range	-40°C to +85°C
Relative Humidity	0 to 95% Noncondensing
Emissions	EN50081-1, ISM Group 1, Class A (Radiated, Conducted)
Immunity	EN50082-1, ISM Group 1, Class A (ESD, RF, EFT)

Ordering Information

Model	Input Range	Output Range	Accuracy ⁽²⁾
100Ω Pt **			
SCM5B35-01	-100°C to +100°C (-148°F to +212°F)	0V to +5V	$\pm 0.12^\circ\text{C}$
SCM5B35-02	0°C to +100°C (+32°F to +212°F)	0V to +5V	$\pm 0.06^\circ\text{C}$
SCM5B35-03	0°C to +200°C (+32°F to +392°F)	0V to +5V	$\pm 0.12^\circ\text{C}$
SCM5B35-04	0°C to +600°C (+32°F to +1112°F)	0V to +5V	$\pm 0.36^\circ\text{C}$
SCM5B35-05	-100°C to +200°C (-148°F to +392°F)	0V to +5V	$\pm 0.18^\circ\text{C}$
10Ω Cu **			
SCM5B35C-01	0°C to +120°C (10Ω at 0°C) (+32°F to +248°F)	0V to +5V	$\pm 0.23^\circ\text{C}$
SCM5B35C-02	0°C to +120°C (10Ω at 25°C) (+32°F to +248°F)	0V to +5V	$\pm 0.23^\circ\text{C}$
SCM5B35C-03	0°C to +160°C (10Ω at 0°C) (+32°F to +320°F)	0V to +5V	$\pm 0.32^\circ\text{C}$
120Ω Ni **			
SCM5B35N-01	0°C to +300°C (+32°F to +572°F)	0V to +5V	$\pm 0.23^\circ\text{C}$

**** RTD Standards**

Type	Alpha Coefficient	DIN	JIS
100ΩPt	0.00385	DIN 43760	JIS C 1604-1989
120Ω Ni	0.00672		
10ΩCu	0.004274		

NOTES:

- (1) "Ω" refers to the resistance in one lead.
 (2) Includes conformity, hysteresis and repeatability.
 (3) Conformity error is $\pm 0.05\%$ Span for SCM5B35N-01.