

SCM5B42

2-Wire Transmitter Interface Modules



Description

Each SCM5B42 2-wire transmitter interface module provides a single channel which accepts a 4 to 20mA process current input and provides a standard +1 to +5V or +2 to +10V output signal (Figure 1). An isolated +20VDC regulated power supply is provided to power the current transmitter. This allows a 2-wire loop powered transmitter to be directly connected to the SCM5B42 without requiring an external power supply. The regulated supply will provide a nominal +20VDC at a loop current of 4mA to 20mA.

The SCM5B42 will provide a 1500V isolation barrier for non-isolated 2-wire field transmitters. It can also be used when additional isolation is required between an isolated 2-wire transmitter and the input stage of the control room computer.

The voltage output is logic switch controlled, which allows these modules to share a common analog bus without the requirement of external multiplexers.

The SCM5B modules are designed with a completely isolated computer side circuit which can be floated to ±50V from Power Common, pin 16. This complete isolation means that no connection is required between I/O Common and Power Common for proper operation of the output switch. If desired, the output switch can be turned on continuously by simply connecting pin 22, the Read-Enable pin, to I/O Common, pin 19.

A precision 20Ω current conversion resistor is supplied with the module. Sockets are provided on the SCMPB01/02/03/04/05/06/07 backpanels to allow installation of this resistor. Extra resistors are available under part number SCMXR1. All field inputs are fully protected from accidental connection of power-line voltages up to 240VAC. The module has a 3dB bandwidth of 100Hz. Signal filtering is accomplished with a six-pole filter, with two poles on the field side of the isolation barrier, and the other four on the computer side.

► Features

- Isolated +20VDC Current Loop Supply
- Provides Isolation for Non-Isolated 2-Wire Transmitters
- High Level Voltage Output +1V to +5V or +2V to +10V
- 1500Vrms Transformer Isolation
- ANSI/IEEE C37.90.1-1989 Transient Protection
- Input Protected to 240VAC Continuous
- 100dB CMR
- 100Hz Signal Bandwidth
- ±0.03% Accuracy
- ±0.005% Linearity
- CSA Certified, FM Approved, CE Compliant
- Mix and Match SCM5B Types on Backpanel

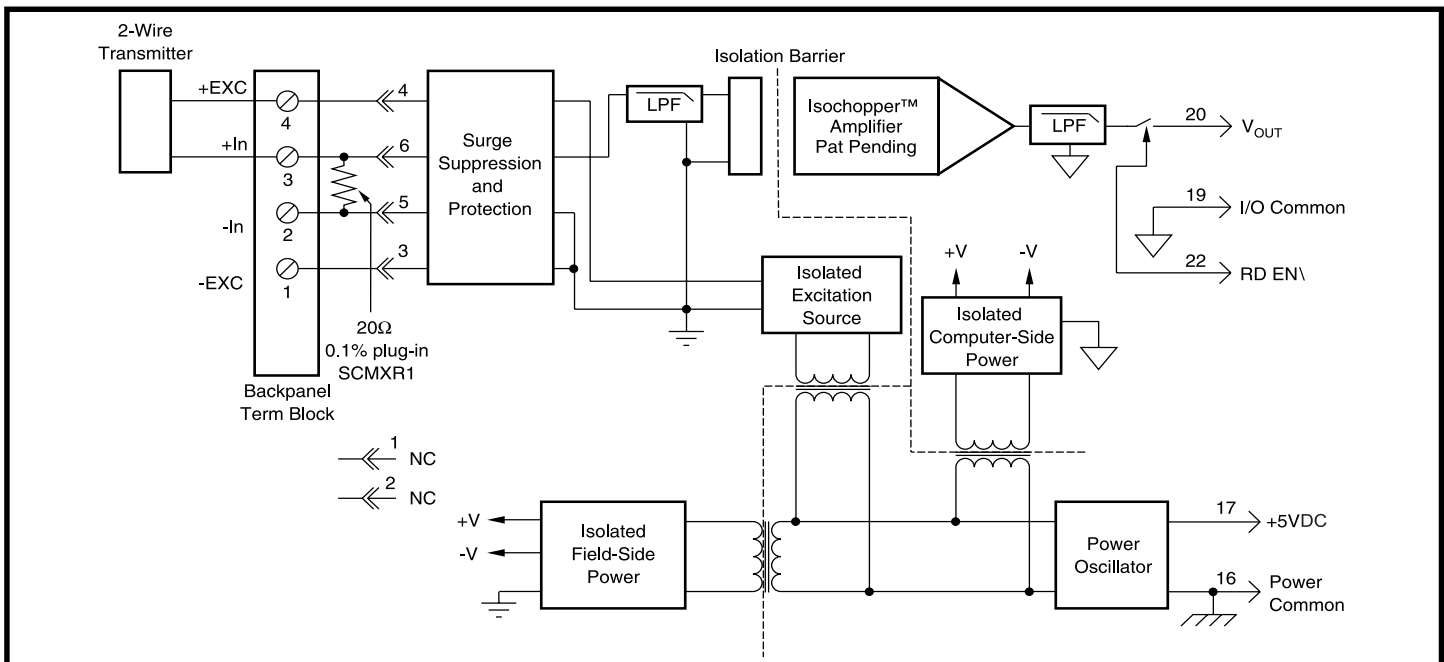

Figure 1: SCM5B42 Block Diagram

Specifications Typical at $T_A = +25^\circ\text{C}$ and +5V power

Module	SCM5B42
Input Range	4mA to 20mA
Input Resistor Value	20.00 Ω
Accuracy	$\pm 0.1\%$
Stability	$\pm 10\text{ppm}/^\circ\text{C}$
Loop Supply Voltage	Nominal 20V at 4mA to 20mA
Isolated Excitation Protection	
Continuous	240Vrms max
Transient	ANSI/IEEE C37.90.1-1989
Input Protection	
Continuous	240Vrms max
Transient	ANSI/IEEE C37.90.1-1989
CMV, Input to Output	
Continuous	1500Vrms max
Transient	ANSI/IEEE C37.90.1-1989
CMR (50 or 60Hz)	100dB
NMR (-3dB at 100Hz)	120dB per Decade Above 100Hz
Accuracy ⁽¹⁾	$\pm 0.03\%$ Span
Nonlinearity	$\pm 0.005\%$ Span
Stability	
Input Offset	$\pm 1\mu\text{V}/^\circ\text{C}$
Output Offset	$\pm 40\mu\text{V}/^\circ\text{C}$
Gain	$\pm 25\text{ppm}/^\circ\text{C}$ of Reading
Noise	
Input, 0.1 to 10Hz	10nArms
Output, 100kHz	500 μV rms
Bandwidth, -3dB	100Hz
Response Time, 90% Span	4mS
Output Range	+1V to +5V or +2V to +10V
Output Resistance	50 Ω
Output Protection	Continuous Short to Ground
Output Selection Time (to $\pm 1\text{mV}$ of V_{OUT})	6 μs at $C_{load} = 0$ to 2000pF
Output Current Limit	+8mA
Output Enable Control	
Max Logic "0"	+0.8V
Min Logic "1"	+2.4V
Max Logic "1"	+36V
Input Current, "0, 1"	0.5 μA
Power Supply Voltage	+5VDC $\pm 5\%$
Power Supply Current	180mA at Transmitter Load of 20mA 100mA at Transmitter Load of 4mA
Power Supply Sensitivity	$\pm 10\mu\text{V}/\%$ RTI ⁽²⁾
Mechanical Dimensions (h)(w)(d)	2.28" x 2.26" x 0.60" (58mm x 57mm x 15mm)
Environmental	
Operating Temp. Range	-40 $^\circ\text{C}$ to +85 $^\circ\text{C}$
Storage Temp. Range	-40 $^\circ\text{C}$ to +85 $^\circ\text{C}$
Relative Humidity	0 to 95% Noncondensing
Emissions	EN50081-1, ISM Group 1, Class A (Radiated, Conducted)
Immunity	EN50082-1, ISM Group 1, Class A (ESD, RF, EFT)

Ordering Information

Model	Input Range	Output Range
SCM5B42-01	4mA to 20mA	+1V to +5V
SCM5B42-02	4mA to 20mA	+2V to +10V

NOTES:

(1) Includes nonlinearity, hysteresis and repeatability.

(2) RTI = Referenced to input.