

SCM5B43



General Purpose Input Modules, with DC Excitation

Description

Each SCM5B43 general purpose input module provides a single channel of transducer input which is filtered, isolated, scaled, and converted to a high level analog voltage output (Figure 1). This voltage output is logic switch controlled, which allows these modules to share a common analog bus without the requirement of external multiplexers.

The SCM5B modules are designed with a completely isolated computer side circuit which can be floated to $\pm 50V$ from Power Common, pin 16. This complete isolation means that no connection is required between I/O Common and Power Common for proper operation of the output switch. If desired, the output switch can be turned on continuously by simply connecting pin 22, the Read-Enable pin, to I/O Common, pin 19.

The SCM5B43 can interface to devices which require a precision 10VDC excitation supply. The 1kHz bandwidth significantly reduces ripple and noise inherent in these devices.

Transducer excitation is provided from the module by a very stable 10V source. The excitation supply is fully isolated, allowing the amplifier inputs to operate over the full range of the excitation voltage. This feature offers significant flexibility in real world applications. Eight full scale input ranges are provided, from $\pm 1V$ to $\pm 10V$, producing $\pm 5V$ full scale output.

The input signal is processed through a pre-amplifier on the field side of the isolation barrier. This pre-amplifier has a gain-bandwidth product of 5MHz and is bandwidth limited to 1kHz. After amplification, the input signal is chopped by a proprietary chopper circuit. Isolation is provided by transformer coupling, again using a proprietary technique to suppress transmission of common mode spikes or surges. The module is powered from +5VDC, $\pm 5\%$.

Special input circuits on the SCM5B43 module provide protection of the signal inputs and the isolated excitation supply up to 240VAC.

► Features

- Interfaces to DC Displacement Transducers and Other Devices Requiring a Stable DC Supply
- High Level Voltage Outputs
- 1500Vrms Transformer Isolation
- ANSI/IEEE C37.90.1-1989 Transient Protection
- Input Protected to 240VAC Continuous
- Fully Isolated Excitation Supply
- 100dB CMR
- 1kHz Signal Bandwidth
- $\pm 0.03\%$ Accuracy
- $\pm 0.005\%$ Linearity
- $\pm 20\mu V/^\circ C$ Drift
- CSA Certified, FM Approved, CE Compliant
- Mix and Match SCM5B Types on Backpanel

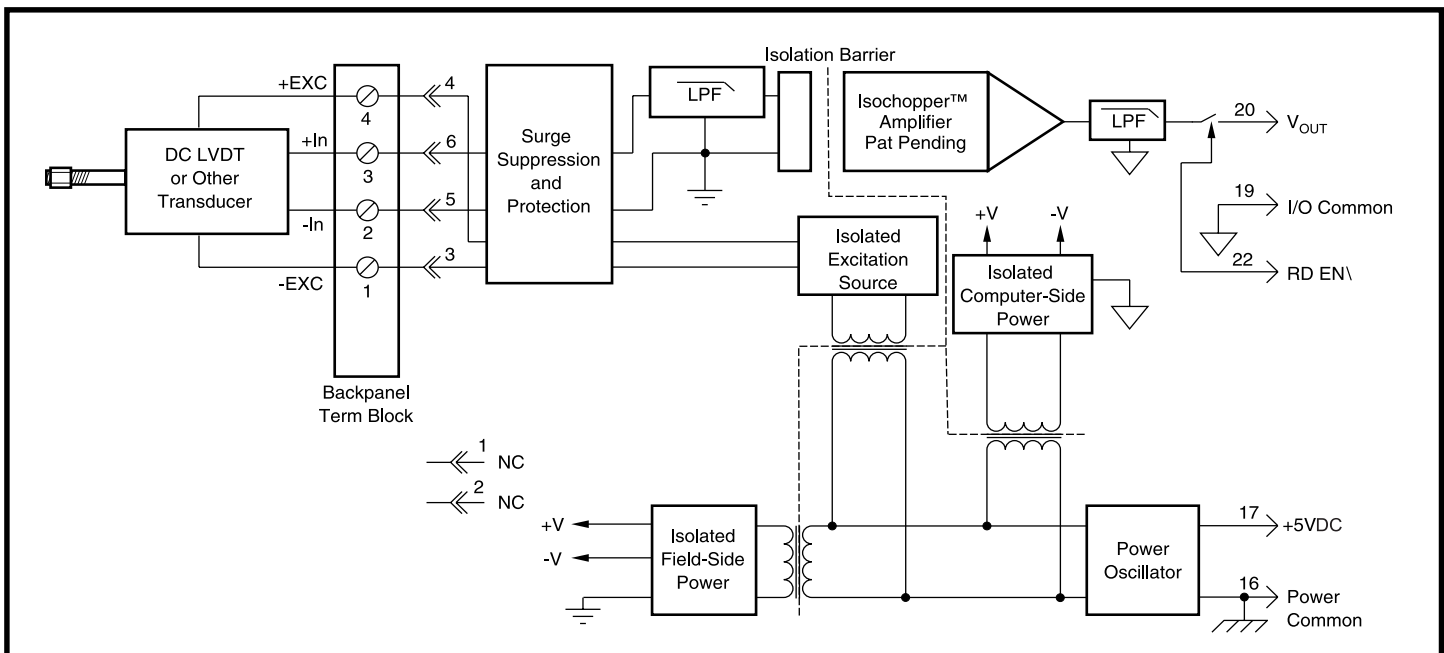

Figure 1: SCM5B43 Block Diagram

Specifications Typical at $T_A = +25^\circ\text{C}$ and +5V power

Module	SCM5B43
Input Range	$\pm 1\text{V to } \pm 10\text{V}$
Input Bias Current	$\pm 0.05\text{nA}$
Input Resistance	
Normal	$2\text{M}\Omega$ (minimum)
Power Off	$2\text{M}\Omega$ (minimum)
Overload	$2\text{M}\Omega$ (minimum)
Input Protection	
Continuous	240Vrms max
Transient	ANSI/IEEE C37.90.1-1989 (formerly IEEE-472)
Excitation Voltage, V_{Exc}	+10.0VDC $\pm 2\text{mV}$
Excitation Current	40mA (maximum)
Excitation Load Regulation	$\pm 5\text{ppm/mA}$
Excitation Stability	$\pm 15\text{ppm}/^\circ\text{C}$
Isolated Excitation Protection	
Continuous	240Vrms max
Transient	ANSI/IEEE C37.90.1-1989 (formerly IEEE-472)
CMV, Input to Output	
Continuous	1500Vrms max
Transient	ANSI/IEEE C37.90.1-1989 (formerly IEEE-472)
CMR (50 or 60Hz)	100dB
NMR (-3dB at 1kHz)	120dB per Decade Above 1kHz
Accuracy ⁽¹⁾	$\pm 0.03\%$ Span,
Nonlinearity	$\pm 0.005\%$ Span
Stability	
Input Offset	$\pm 20\mu\text{V}/^\circ\text{C}$
Output Offset	$\pm 40\mu\text{V}/^\circ\text{C}$
Gain	$\pm 50\text{ppm}/^\circ\text{C}$
Noise	
Input, 0.1 to 10Hz	$0.4\mu\text{Vrms}$
Output, 100kHz	5mVp-p
Bandwidth, -3dB	1kHz
Response Time (to 90% final value)	750 μs
Output Range	$\pm 5\text{V}$
Output Resistance	50Ω
Output Protection	Continuous Short to Ground
Output Selection Time (to $\pm 1\text{mV}$ of V_{OUT})	6.0 μs at $C_{\text{load}} = 0$ to 2000pF
Output Current Limit	$\pm 8\text{mA}$
Output Enable Control	
Max Logic "0"	+0.8V
Min Logic "1"	+2.4V
Max Logic "1"	+36V
Input Current, "0, 1"	0.5 μA
Power Supply Voltage	+5VDC $\pm 5\%$
Power Supply Current	200mA at Full Exc. Load, 100mA at No Exc. Load
Power Supply Sensitivity	$\pm 200\mu\text{V}/\%$ RTI ⁽²⁾
Mechanical Dimensions (h)(w)(d)	2.28" x 2.26" x 0.60" (58mm x 57mm x 15mm)
Environmental	
Operating Temp. Range	-40°C to $+85^\circ\text{C}$
Storage Temp. Range	-40°C to $+85^\circ\text{C}$
Relative Humidity	0 to 95% Noncondensing
Emissions	EN50081-1, ISM Group 1, Class A (Radiated, Conducted)
Immunity	EN50082-1, ISM Group 1, Class A (ESD, RF, EFT)

Ordering Information

Model	Maximum Input	Output
SCM5B43-01	$\pm 1\text{V}$	$\pm 5\text{V}$
SCM5B43-02	$\pm 2\text{V}$	$\pm 5\text{V}$
SCM5B43-03	$\pm 3\text{V}$	$\pm 5\text{V}$
SCM5B43-04	$\pm 4\text{V}$	$\pm 5\text{V}$
SCM5B43-05	$\pm 5\text{V}$	$\pm 5\text{V}$
SCM5B43-06	$\pm 6\text{V}$	$\pm 5\text{V}$
SCM5B43-07	$\pm 7\text{V}$	$\pm 5\text{V}$
SCM5B43-08	$\pm 8\text{V}$	$\pm 5\text{V}$
SCM5B43-09	$\pm 9\text{V}$	$\pm 5\text{V}$
SCM5B43-10	$\pm 10\text{V}$	$\pm 5\text{V}$

NOTES:

(1) Includes excitation error, nonlinearity, hysteresis and repeatability.

(2) RTI = Referenced to input.