

SCM5B45

Frequency Input Modules



Description

Each SCM5B45 frequency input module provides a single channel of frequency input which is isolated and converted to a high level analog voltage output. This voltage output is logic switch controlled, which allows these modules to share a common analog bus without the requirement of external multiplexers (Figure 1).

The frequency input signal can be a TTL level signal or a zero-crossing signal. Terminal 3 on the field-side terminal block is the “common” or ground connection for input signals. A TTL signal is connected from terminal 2 to terminal 3, while a zero-crossing signal is connected from terminal 4 to terminal 3. Input circuitry for each of the signal types has hysteresis built in. An input signal must cross entirely through the hysteresis region in order to trigger the threshold comparator.

A 5.1V excitation is available for use with magnetic pick-up or contact-closure type sensors. The excitation is available on pin 1 and the excitation common is pin 3.

The SCM5B modules are designed with a completely isolated computer side circuit which can be floated to $\pm 50V$ from Power Common, pin 16. This complete isolation means that no connection is required between I/O Common and Power Common for proper operation of the output switch. If desired, the output switch can be turned on continuously by simply connecting pin 22, the Read-Enable pin, to I/O Common, pin 19.

A special circuit in the input stage of the module provides protection against accidental connection of power-line voltages up to 240VAC.

► Features

- Accepts Frequency Inputs of 0 to 100kHz
- Provides High Level Voltage Outputs
- TTL Level Inputs
- 1500 Vrms Transformer Isolation
- ANSI/IEEE C37.90.1-1989 Transient Protection
- Input Protected to 240VAC Continuous
- $\pm 0.05\%$ Accuracy
- CSA Certified, FM Approved, CE Compliant
- Mix and Match SCM5B Types on Backpanel

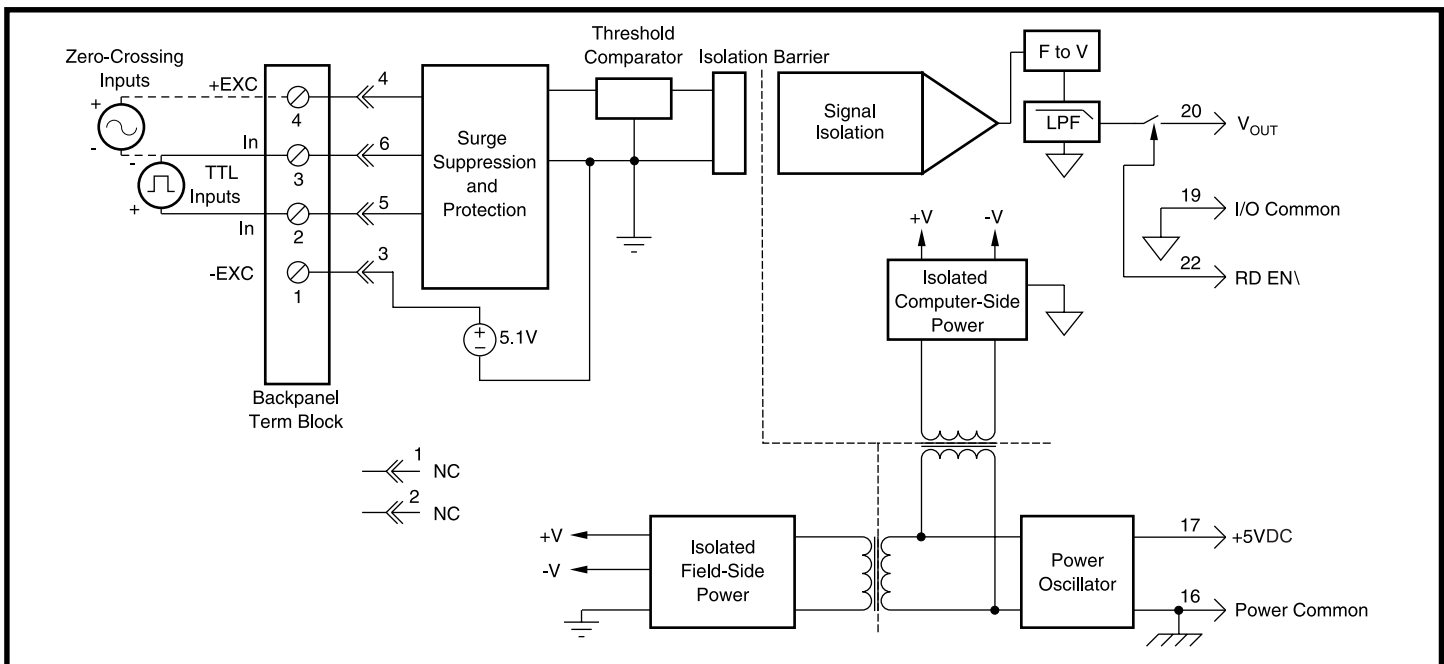

Figure 1: SCM5B45 Block Diagram

Specifications Typical at $T_A = +25^\circ\text{C}$ and +5V power

Module	SCM5B45
Input Range	0 to 100kHz
Input Threshold	Zero Crossing
Minimum Input	60mVp-p
Maximum Input	350Vp-p
Minimum Pulse Width	4 μ s
TTL Input Low	0.8V max
TTL Input High	2.4V min
Input Hysteresis	
Zero Crossing	$\pm 20\text{mV}$ ($\pm 400\text{mV}$ on -2x models)
TTL	1.5V
Input Resistance	
Normal	100k Ω
Power Off	100k Ω
Overload	100k Ω
Input Protection	
Continuous	240Vrms max
Transient	ANSI/IEEE C37.90.1-1989
Excitation	+5.1V at 8mA max
CMV, Input to Output	
Continuous	1500Vrms max
Transient	ANSI/IEEE C37.90.1-1989
CMR (50 or 60Hz)	120dB
Accuracy ⁽¹⁾	$\pm 0.05\%$ Span
Nonlinearity	$\pm 0.02\%$ Span
Stability	
Offset	$\pm 8\text{ppm}/^\circ\text{C}$
Gain	$\pm 40\text{ppm}/^\circ\text{C}$
Noise	
Output Ripple	<10mVp-p at Input >2% span
Response Time (0 to 90%)	
SCM5B45-01, -02	300ms
SCM5B45-03	170ms
SCM5B45-04, -05	90ms
SCM5B45-06, -07, -08	20ms
Output Range	0V to +5V
Output Resistance	50 Ω
Output Protection	Continuous Short to Ground
Output Selection Time (to $\pm 1\text{mV}$ of V_{OUT})	6 μ s at $C_{\text{load}} = 0$ to 2000pF
Output Current Limit	+8mA
Output Enable Control	
Max Logic "0"	+0.8V
Min Logic "1"	+2.4V
Max Logic "1"	+36V
Input Current, "0,1"	0.5 μ A
Power Supply Voltage	+5VDC $\pm 5\%$
Power Supply Current	110mA
Power Supply Sensitivity	$\pm 150\mu\text{V}/\%$ RTO ⁽²⁾
Mechanical Dimensions (h)(w)(d)	2.28" x 2.26" x 0.60" (58mm x 57mm x 15mm)
Environmental	
Operating Temp. Range	-40 $^\circ\text{C}$ to +85 $^\circ\text{C}$
Storage Temp. Range	-40 $^\circ\text{C}$ to +85 $^\circ\text{C}$
Relative Humidity	0 to 95% Noncondensing
Emissions	EN50081-1, ISM Group 1, Class A (Radiated, Conducted)
Immunity	EN50082-1, ISM Group 1, Class A (ESD, RF, EFT)

Ordering Information

Model	Input Range	Output Range	Zero Crossing Hysteresis
SCM5B45-01	0 to 500Hz	0V to +5V	$\pm 20\text{mV}$
SCM5B45-02	0 to 1kHz	0V to +5V	$\pm 20\text{mV}$
SCM5B45-03	0 to 3kHz	0V to +5V	$\pm 20\text{mV}$
SCM5B45-04	0 to 5kHz	0V to +5V	$\pm 20\text{mV}$
SCM5B45-05	0 to 10kHz	0V to +5V	$\pm 20\text{mV}$
SCM5B45-06	0 to 25kHz	0V to +5V	$\pm 20\text{mV}$
SCM5B45-07	0 to 50kHz	0V to +5V	$\pm 20\text{mV}$
SCM5B45-08	0 to 100kHz	0V to +5V	$\pm 20\text{mV}$
SCM5B45-21	0 to 500Hz	0V to +5V	$\pm 400\text{mV}$
SCM5B45-22	0 to 1kHz	0V to +5V	$\pm 400\text{mV}$
SCM5B45-23	0 to 3kHz	0V to +5V	$\pm 400\text{mV}$
SCM5B45-24	0 to 5kHz	0V to +5V	$\pm 400\text{mV}$
SCM5B45-25	0 to 10kHz	0V to +5V	$\pm 400\text{mV}$
SCM5B45-26	0 to 25kHz	0V to +5V	$\pm 400\text{mV}$
SCM5B45-27	0 to 50kHz	0V to +5V	$\pm 400\text{mV}$
SCM5B45-28	0 to 100kHz	0V to +5V	$\pm 400\text{mV}$

NOTES:

(1) Includes nonlinearity, hysteresis and repeatability.

(2) RTO = Referenced to Output.